

YUEQING HONGYI ELECTRONICS CO., LTD
乐清市宏一电子有限公司

SPECIFICATION FOR APPROVAL

承认书

CUSTOMER 客户名称	
DESCRIPRION 产品名称	20095 /20096 板对板系列连接器
ITEM NO 编 号	HY-B20008 (B61)
DATE 日 期	2022-09-13

CUSTOMER ACKNOWLEDGEMENT SEAL

客 户 承 认 印 签

(APPROVAL) 核准	(ENGINEERING) 工程	(PURCHASE) 采购	(QUALITY) 品质
承认结果： <input type="checkbox"/> 通过 <input type="checkbox"/> 不通过 <input type="checkbox"/> 重新送样			

IS09001

IS014001

IS045001

IATF16949 体系认证

ADD: No. 30, Wenjing Road, Houyu village, Shifan street, Yueqing City, Zhejiang Province

地此：浙江省乐清市石帆街道后屿文景路 30 号

TEL:0577-62380521

FAX: 0577-62381979 P.C:325608

http: //www.zhehongyi.com

E-MAIL:yaohongxiao88@126.com

产 品 承 认 书 目 录

1、封面	1-1
2、修订履历	2-2
2、目录	3-3
3、技术规范	4-9
4、产品图纸	10-11

PRODUCT SPECIFICATION

产品规范

1、Scope

适用范围

This specification includes the following specifications, including the specification of 2.00mm pitch 20095/20096 Board to board series connector
本规范包括下列此种规格包括 2.00mm 间距 20095/20096 板对板系列连接器规格说明

2、Appearance and Dimension

外观及尺寸

2.1 Appearance: Product surface without defect、dirt、crack、and mechanical damage, Contact without rust, plating not oxidized and not peeled.

产品表面不应有对制品有害的缺陷、污垢、裂痕及机械损伤；接触件无锈蚀、镀层氧化脱落等现象

2.2 Dimension: According to drawings

外形尺寸：依照附图

3、Disposal of Material and surface

材料与表面处理

Specification 规格内容	Material 材质	Finish 表面处理	Environmental protection grade 环保等级
Wafer 20095 针座	Plastic 塑壳	LCP UL94V-0	Color: Beige 颜色: 米色
	Contact 插针	Phosphor bronze 磷铜 厚 0.40mm	Tin Mist: 2.5~5 μm 镀锡: 2.5~5 μm
	Solder tab 焊护耳	Phosphor bronze 磷铜 厚 0.15mm	Tin Mist: 2.5~5 μm 镀锡: 2.5~5 μm
Wafer 20096 针座	Plastic 塑壳	LCP UL94V-0	Color: Beige 颜色: 米色
	Contact 插针	Phosphor bronze 磷铜 厚 0.30mm	Tin Mist: 2.5~5 μm 镀锡: 2.5~5 μm
	Solder tab 焊护耳	Phosphor bronze 磷铜 厚 0.15mm	Tin Mist: 2.5~5 μm 镀锡: 2.5~5 μm

RoHS2.0

4、Ratings and applicable wires

额定等级

Item 项目	Standard 规格
Rated Voltage 额定电压	250V AC/DC
Rated Current 额定电流	1A AC/DC
Ambient temperature Range 使用温度范围	-25°C- +85°C

5、Electrical Performance

电气性能

N0. 序号	Ltem 项目	Test mode 试验方法	Requirement 技术要求
5.1	Contact Resistance 接触电阻	Male female cooperation, open voltage less than 20mV, current 100mA detection connector at both ends 公母配合, 开放电压20mV 以下, 电流100mA 检测连接器连接器两端	Initial:30mΩ Max 初始: 30mΩ Max After Test: 40mΩ Max 试验后: 40mΩ Max
5.2	Withstand voltage 耐电压	Mate connectors, apply 1500V AC for 1 minute between adjacent terminal or ground 公母配合, 在相邻端子, 端子与地片之间, 使用1500V 的交流电1 分钟, 检测连接器	No Breakdown and Flashover 外观无损伤, 无打火花
5.3	Insulation Resistance 绝缘电阻	Mate connectors, apply 500V DC between adjacent terminal or ground 公母配合, 在相邻端子, 端子与地片之间, 使用500V 的直流电, 检测连接器	1000MΩ Min

6、机械性能

Mechanical Performance

N0. 序号	Ltem 项目	Test mode 试验方法	Requirement 技术要求
6.1	Insertion force 总插入力	Insert force at a rate of 25.4 ± 3 mm per minute 以每分钟 25.4 ± 3 mm 的速率插入力	20N Max
6.2	Withdraw Force 总拔出力	Pull out force at a rate of 25.4 ± 3 mm per minute 以每分钟 25.4 ± 3 mm 的速率拔出力	5N Min
6.3	Pin Retention Force Pin 针保持力	Apply axial push force at the speed rate of 25.4 ± 3 mm/minute 以每分 25.4 ± 3 mm 的速率, 将 PIN 针从 Wafer 内轴向拔出力	Per contact: 5N Min 单一接触点: 5N Min

7、Endurance Characteristics:

环境性能

N0. 序号	Ltem 项目	Test mode 试验方法	Requirement 技术要求
7.1	Repeated Insertion/ Withdrawal 重复插拔	When mated up to 30 cycles repeatedly by the rate of 10 cycles per minute 以每分钟不超过 10 次的速率, 将公母插拔 30 次	Contact Resistance 接触电阻 40 m Ω Max
7.2	Temperature Rise 温升测试	Mating connectors shall be energized at rating current until thermal stability is achieved, and then measured the temperature rise 公母连接器配合后, 加载额定电流直到温度上升到稳定 状态, 然后再测量温升	Temperature Rise 温升测试 30 $^{\circ}$ C Max

7、Endurance Characteristics:

环境性能

NO. 序号	Item 项目	Test mode 试验方法	Requirement 技术要求	
7.3	Vibration test 振动测试	Amplitude: 1.5mm P-P Sweep time: 10~55~10 HZ in 1 minute Duration: 2 hours in each X.Y.Z axials 振幅: 1.5mm P-P 时间: 10~55~10 HZ in 1 minute 持续时间: 每轴向 2 小时	Appearance 外观	No damage 无异常
			Contact Resistance 接触电阻	40 mΩ Max
			Discontinuity 瞬断	1 micro-second Max.
7.4	Heat Resistance 耐热性	85±2℃,96 hours	Appearance 外观	No damage 无异常
			Contact Resistance 接触电阻	40 mΩ Max
7.5	Cold Resistance 耐寒性	-25±3℃,96 hours	Appearance 外观	No damage 无异常
			Contact Resistance 接触电阻	40 mΩ Max
7.6	Humidity 耐湿性	Temperature: 60±2℃ Relative Humidity: 90~95% Duration: 96 hours 温度: 60±2℃ 湿度: 90~95%(RH) 持续时间: 96 hours	Appearance 外观	No damage 无异常
			Contact Resistance 接触电阻	40 mΩ Max
			Withstand Voltage 耐电压	No Breakdown and Flashover 外观无损伤, 无打火花
			Insulation Resistance 绝缘电阻	1000MΩ Min

NO. 序号	Ltem 项 目	Test mode 试验方法	Requirement 技术要求	
7.7	温度变化 Temperature Cycling	5 cycles of: a) -25°C 30 minutes b) +85°C 30 minutes	Appearance 外观	No damage 无异常
		从-25°C持续30 分钟升至+85°C持续30 分钟,循环5 次	Contact Resistance 接触电阻	40 mΩ Max
7.8	Salt spray 盐雾	24±1 hours exposure to a salt spray from the 5±1% solution at 35±2°C	Appearance 外观	No damage 无异常
		在温度35±2°C, 盐水浓度5±1%下, 盐水喷雾24±1 小时	Contact Resistance 接触电阻	40 mΩ Max
7.9	Solder ability 焊锡附着性	Soldering Time: 3-5sec solder Temperature: 245±5°C 焊接时间: 3-5 秒 焊接温度: 245±5°C	Solder Wetting 焊料润湿	95%of immersed area must show no voids,pin holes. 浸渍面积需 95% 以上
7.10	Solder- Resistance 焊锡耐热性	SMT reflow soldering heat resistance range: Soldering time:5~10sec solder: Temperature:255±5°C SMT 型回流焊接耐热范围: 焊接时间: 5~10 秒. 焊接温度: 255±5°C Please refer to the 9.1 solder reflow temperature curve 回流焊请参考 9.1 温度曲线图	Appearance 外观	No damage 无异常

8、 SMT lead-free process temperature curve SMT 无铅工艺温度曲线

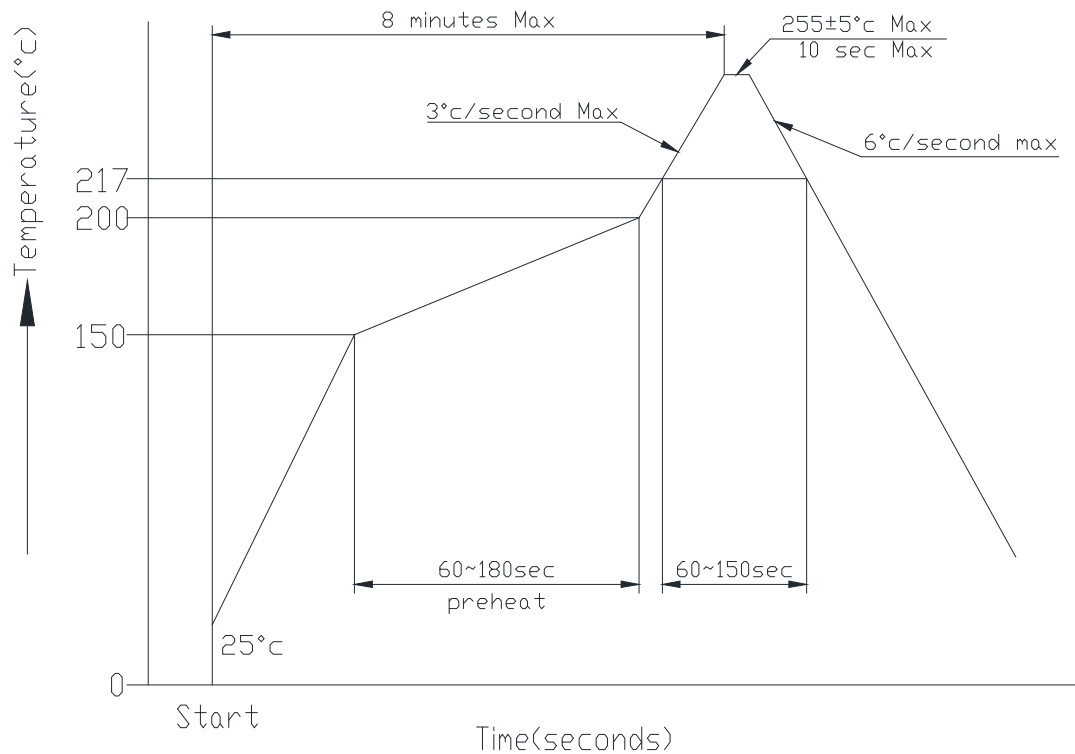

Notes: Please check the reflow soldering condition by your own devices beforehand. Because the condition changes by the soldering devices, P.C. boards, and so on

注记: 由于 P.C 板等焊接装置改变条件,所以请预先用自己的装置检查回流焊的条件

10、 Caution 注意事项

plastic because of characteristics with water after package is opened should avoid exposure to, the temperature is higher than 30 °C, humidity is higher than 60%RH in the environment, and in the 24 hours after all after use, to prevent subsequent reflow, wave soldering process to produce foaming phenomenon of deformation

塑料因具有吸水之特性包装拆封后应避免暴露于, 温度高于 30°C, 湿度高于 60%RH 的环境中, 并在拆封后 24 小时内全数使用完毕, 防止后续回流焊、波峰焊制程产生起泡变形现象

REV.	DATE	ECN NO.	变更内容 DESCRIPTION	制图 DRAWN

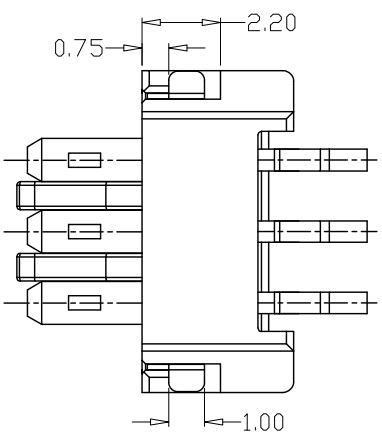
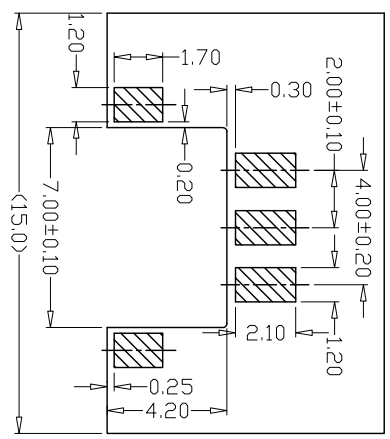
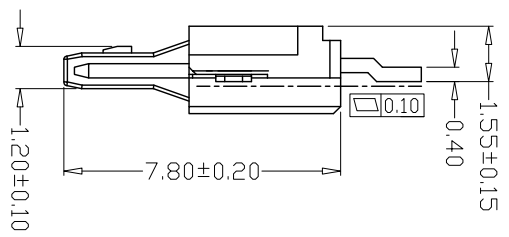
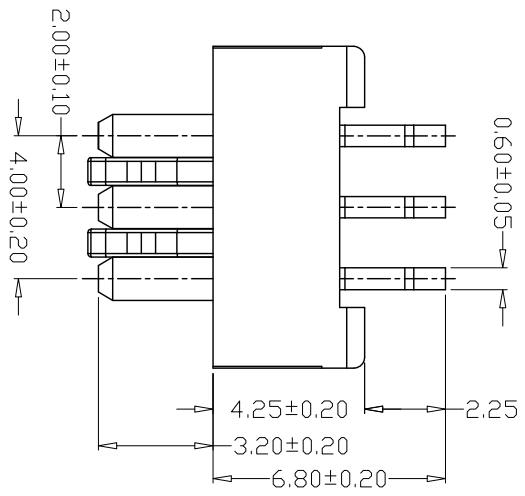
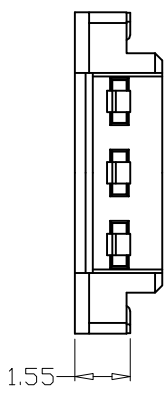
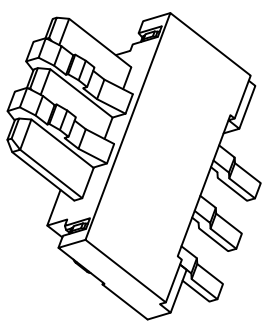

SPECIFICATIONS

- 1、 Current Rating: 1A AC, DC
- 2、 Voltage Rating: 250V AC, DC
- 3、 Temperature Range: -25°C~+85°C
- 4、 Contact Resistance: 30mΩ Max
- 5、 Insulation Resistance: 1000MΩ Min
- 6、 Withstanding Voltage: 1500V AC/minute
- 7、 Material: Wafer LCP, UL94V-0
PIN Phosphor bronze Tin-plated
Solder tads Phosphor bronze Tin-plated

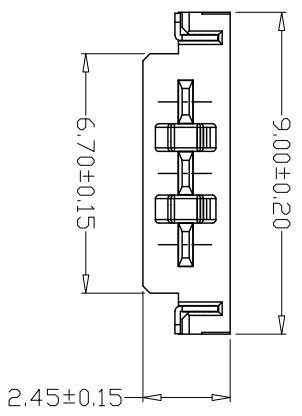

GENERAL TOLERANCE		制图 Mapping	料号 PART NO.	版本 REV.
X \pm 0.25	X \pm 2°	张迎春	B20008-3AWB	A
X \pm 0.25	X \pm 1°	审核 钱岳生	20095卧式(长)	页次 1/1
.XX \pm 0.15	.XX \pm 0.5°	核准 张名	客户料号	SHEET
.XXX \pm 0.10	.XXX \pm 0.5°	Approved 2022-09-13	CITM. NO.	
		单位 Units	MM	比例 SCALE
			1:1	

乐清市宏一电子有限公司
Yueqing HongYi Electronics Co., Ltd

版本 REV.	日期 DATE	ECN NO.	变更内容 DESCRIPTION	制图 DRAWN
------------	------------	---------	---------------------	-------------

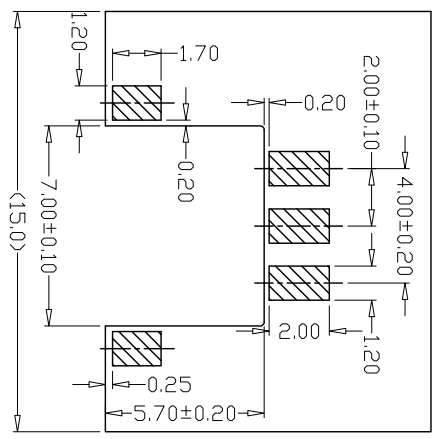
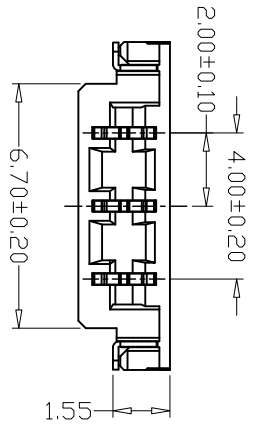

PCB LAYOUT

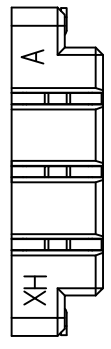
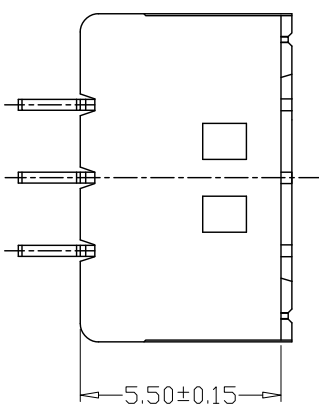
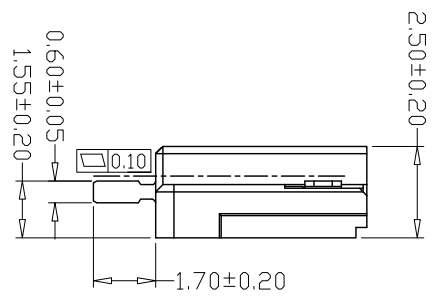
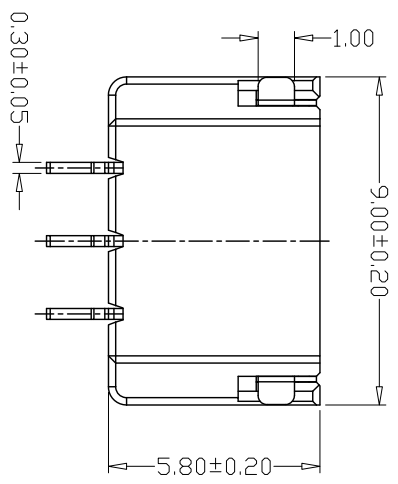
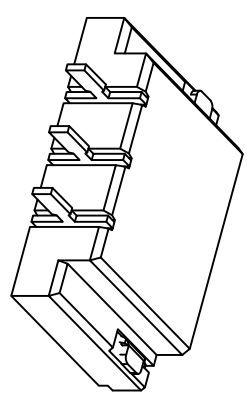

SPECIFICATIONS

- 1、Current Rating: 1A AC, DC
- 2、Voltage Rating: 250V AC, DC
- 3、Temperature Range: -25°C~+85°C
- 4、Contact Resistance: 20mΩ Max
- 5、Insulation Resistance: 1000MΩ Min
- 6、Withstanding Voltang: 1500V AC/minute
- 7、Material: Wafer LCP, UL94V-0
PIN Phosphor bronze Tin-plated
Solder tads Phosphor bronze Tin-plated

GENERAL TOLERANCE		制图 Mapping	张迎春	料号 PART NO.	B200008-3AWB1	版本 REV.	A
X \pm 0.25	X \pm 2°	审核 Audit	钱岳生	品名 TITLE	20096贴片(短)	页次	1/1
X \pm 0.25	X \pm 1°	核准 Approved	张名	客户料号 WAFER SMT TYPE		SHEET	1/1
.XX \pm 0.15	.XX \pm 0.5°	单位 Units	2022. 09. 13	CITM. NO.			
.XXX \pm 0.10	.XXX \pm 0.5°	MM	比例 SCALE	1:1	乐清市宏一电子有限公司 Yueqing Hongyi Electronics Co., Ltd		